



PowerBox Systems®

World Leaders in RC
Power Supply Systems



POWER PAK

Dear **PowerBox** pilot,

We are delighted that you have chosen a power supply system from the **PowerPak** series. These high-quality energy storage units combine maximum power density and security in a rugged, compact case. **PowerPaks** are very flexible: thanks to the mounting frame supplied as standard, they are easy to install, and can be swapped between models.

The **PowerPaks 2.5X2** are available in two versions: **ECO** and **PRO**. The two variants differ only in the charging technology – the performance of the cells is always the same. The **PRO** version features integral charging circuitry and a voltage monitor, whereas the **ECO** version is charged using a conventional Li-Ion charger. Balancers are standard in both versions.

The self-discharge feature originally fitted is to be discontinued as of Winter 2018, this function is now handled by the supplied **BattLife Guard!**

We hope you have years of pleasure and success with your **PowerPak**.

FEATURES:

- + integral charge / security electronics (**PRO** version)
- + can be charged using mains PSU or 12 V adapter (**PRO** version)
- + integral voltage monitor using external LED (**PRO** version)
- + Packs assembled using the latest generation of high-current Li-Ion batteries
- + two different versions: **ECO** and **PRO**
- + two different output voltages: 8.4 V and 12.6 V
- + maximum discharge current 30 A
- + for use as receiver power supplies or turbine batteries
- + integral balancer
- + integral charge socket
- + rugged case protects cells from external influences
- + Packs are held securely in the standard mounting frame with quick-release latch
- + Batteries can remain in the model for charging
- + easy, swift battery swapping
- + economical cell exchange service

CONTENT

1. Installation, connections	3
2. Charging	4
3. Cell care	7
4. Voltage indicator, PRO version	7
5. Cell exchange, Service	8
6. Specification	8
7. Dimensions	9
8. Set contents	10
9. Service.....	10
10. EU Declaration of Conformity.....	10
11. Guarantee conditions	11
12. Safety information.....	12
13. Liability exclusion	13

1. INSTALLATION, CONNECTIONS

PowerPaks are installed in the model using the mounting frame, which should be attached to a surface in the model which is as rigid as possible. Fit the rubber grommets and brass spacers as shown in the illustration below:



TIP: For best support put the flatten side down!

It is important to bear in mind that high G-forces and severe vibration can occur in our models. This means that the mounting surface has to be capable of withstanding several times the weight of the battery. The three-point arrangement of the mounting frame's retaining screws allows the **PowerPak** to be installed on surfaces which are not absolutely flat.

The **PowerPak** is connected to the consumer unit using the patch leads (MPX / JR or MPX / MPX) supplied in the set. It is important that no substantial length of cable should lie loose in the model, as this could place mechanical strain on the connections.

Connections for the two versions - **ECO** (left) and **PRO** (right):

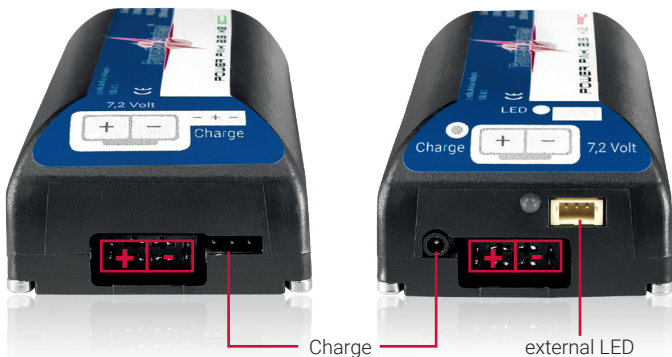

Note: PowerPaks are available in **2S** form for receiver power supplies, and in **3S** form for turbine power supplies.

Do not confuse the two versions! If you accidentally connect a **PowerPak X3** to a receiver, the high voltage will destroy the electronics. To help you differentiate between the versions, the front of the **PowerPak X3** is marked **red**.

2. CHARGING

PowerPak 2.5X2 is available in two versions: **PRO** and **ECO**; the basic difference between the types is the method of charging. The **PRO** version has its own integral charge circuit, matched specifically to the installed cells,

whereas the **ECO** version is designed to be charged using an external Li-Ion / LiPo charger.

Both versions feature integral balance circuits which ensure that individual cells are not overcharged, as even Li-Ion cells are extremely vulnerable to this state. Unbalanced cells can drift apart in condition, leading to loss of capacity; accurate balancing also effectively eliminates this danger.

2.1 CHARGING THE PRO VERSION

To charge the **PRO** version you can use either the 110 / 220 V mains PSU or the 12 V car adapter, either of which we can supply separately; both units can be used to charge two **PowerPaks** simultaneously. The batteries are simply plugged in like any conventional mobile phone, after which the charge process is completed fully automatically.

When the charge lead is plugged in, the circuit first checks the battery's state of charge before initiating the charge process. The integral LED - and the external LED, which can be plugged in if you wish - glows red when the battery is on charge, and green when the charge process is complete.

A flashing red LED indicates an error, such as exceeding the maximum permitted charge duration. If this should happen, please disconnect the battery from the charger, then plug it in again. This causes the electronics to recheck the state of the battery, and the charge process will restart if necessary.

Our accessory range also includes charge lead extensions (e.g. Order No. 5460), which can be useful for recharging batteries which are installed in inaccessible locations.

Note re. Turbine PowerPak 3X PRO: you may find that the charge process does not conclude in the normal way with this **PowerPak** when using the 12 V car adapter. The reason for this is that the voltage of the car battery may not be sufficient, depending on its state of charge. In our experience the battery is 95 % fully charged at this point, but the LED remains red. Nevertheless the battery can then be used in the normal way.

2.2 CHARGING THE ECO VERSION

To charge the **ECO** version you will need a charger intended for Li-Ion or LiPo batteries. It is essential to set the charger correctly to suit the **PowerPak** you wish to charge.

CAUTION: It is absolutely essential to set the correct final charge voltage (cut-off voltage)! If you charge these batteries with the cut-off voltage set too high, the result could be a fire!

PowerPak X2 batteries have a nominal voltage of 7.2 V, the final charge voltage is 8.2 V.

The optimum charge rate for the **ECO** version is 0.5 C. If you are using a **PowerPak 2.5** this means a charge current of 1.25 A. This rate of charge guarantees a long useful life for the battery. However, it is permissible to charge at 1C (2.5 A) in exceptional cases.

Connect the **PowerPak** to your battery charger using the charge lead (Order No. 1763/60) which is available separately. Check that polarity is correct at the charger. The Uni connector on the **PowerPak** can be plugged in either way round, as the positive (+) terminal is always in the centre.

CAUTION: Important information regarding **PowerBox** battery backers and other dual power supplies:

- 1) **All** dual power supply units currently available commercially control the charge current on the negative side.
- 2) **All** dual power supply units currently available commercially feature a permanent connection between the negative terminals of the two batteries.

These two facts make it impossible to charge two batteries simultaneously while they are plugged into a dual power supply unit! The following options are available:

- a) Disconnect one of the two batteries from the dual power supply unit for charging
- b) Charge the batteries in turn, i.e. one after the other

If you ignore the points stated above, the short-circuit situation may damage the battery charger! These points do not apply to the **PRO** version if the integral charge circuit is used.

3. CELL CARE

The useful life of **PowerPaks** can be extended significantly by handling them correctly; this also enhances the safety of the cells.

The self-discharge circuit built into earlier **PRO** versions is to be discontinued as of Winter 2018; the new version can be identified by a dot on the underside. This feature required a micro-controller whose idle current in many cases caused cells to be deep-discharged if the battery was stored for a long period. The circuit also proved to be incompatible with the charging electronics of turbine generators.

The following applies to the **PRO** and **ECO** versions:

The self-discharge rate of our **PowerPaks** is very low, which means that, after a flying session, it is best to store the model with the batteries part-discharged, and then recharge them before the next outing.

In both versions the useful life of the cells can be extended by discharging the cells using the BattLife Guard to storage voltage (approx. 7.6 to 7.8 V) before any protracted period of storage.

Note: A frequently asked question is this: "how can I tell whether the battery is still in good condition?"

With Lithium cells this is very easy to determine: give the pack a full charge, then discharge it to 3.0 V per cell using a suitable Lilon / LiPo battery charger. If the measured capacity is greater than 80 % of its nominal capacity, the **PowerPak** is still in usable condition. If the discharged capacity falls below this level, then please refer to Point 5.

4. VOLTAGE INDICATOR, PRO VERSION

In addition to the integral charge and the balancers, the **PRO** version features an integral voltage indicator. When the **PowerPak PRO** is in the charged state, the internal and external LEDs are switched off. The red LED lights up as soon as the battery capacity falls to 30 %.

5. CELL EXCHANGE, SERVICE

If, after a period of a several years, the cells in a **PowerPak** are exhausted, we offer an economical cell exchange service combined with a check of the electronics. Simply send the **PowerPak** to our Service address (p. 11).

All PowerPaks have passed rigorous testing to gain certification in accordance with UN38.3, and the manufacturing process is monitored by the quality management team. Thanks to this procedure these batteries can legally be shipped by air freight.

For current and additional information on this subject please visit our support forum: www.forum.powerbox-systems.com

Note: For reasons of safety it goes without saying that batteries which have clearly suffered mechanical damage must not be sent back to us. If this applies to you, please contact us to discuss further action.

6. SPECIFICATION

Battery type	PowerPak 2.5x2	PowerPak 5.0x2	PowerPak 2.5x3
Nominal capacity	2500 mAh	5000 mAh	2500 mAh
Nominal voltage	7.2 V	7.2 V	11.1 V
Charge cut-off voltage	8.2 V	8.2 V	12.6 V
Charge voltage (PRO)	9–17 V	9–17 V	13.5–17 V
Weight	125 g	235 g	191 g
Weight of mounting frame	8 g		
Discharge temperature range	0° C to 60 °C		
Charge temperature range	0° C to 40 °C		

7. DIMENSIONS

Height: 26 mm

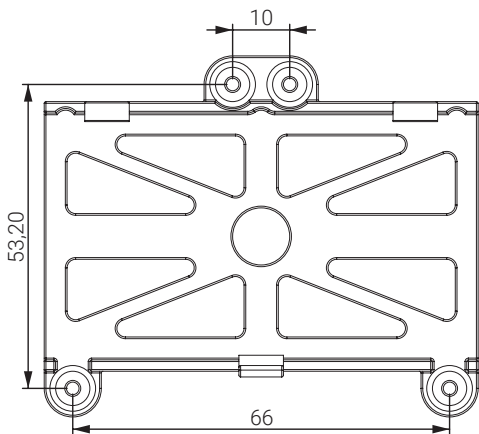
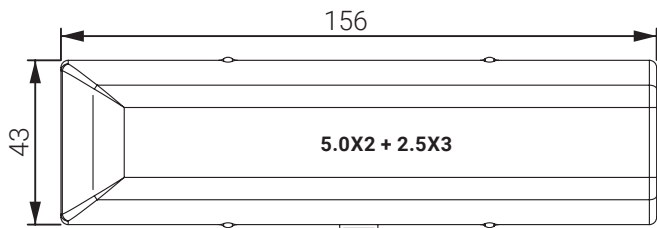
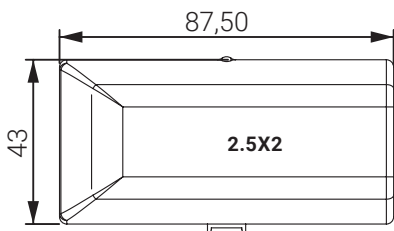

8. SET CONTENTS

- PowerPak
- Mounting frame
- 1 x MPX / MPX connecting lead
- 4 x rubber grommets
- 4 x brass tubular spacers
- 4 x screws
- BattLife Guard (PRO Version)
- Operating instructions

9. SERVICE NOTE

We make every effort to provide a good service to our customers, and have now established a Support Forum which covers all queries relating to our products. This helps us considerably, as we no longer have to answer frequently asked questions again and again. At the same time it gives you the opportunity to obtain assistance all round the clock, and even at weekends. The answers come from the **PowerBox team**, which guarantees that the answers are correct.

Please use the Support Forum **before** you contact us by telephone.

You will find the forum at the following address:
www.forum.powerbox-systems.com



10. EU DECLARATION OF CONFORMITY

This device complies with the essential requirements and other relevant provisions of Directives 2011/65/EU + 2015/863/EU (RoHS) and 2014/30/EU (EMC). The EU Declaration of Conformity for the **PowerPaks** can be found under the following link:

www.powerbox-systems.com/en/content/certificates

11. GUARANTEE CONDITIONS

At **PowerBox-Systems** we insist on the highest possible quality standards in the development and manufacture of our products. They are guaranteed **“Made in Germany”!**

That is why we are able to grant a **24 month guarantee** on our **PowerPaks** from the initial date of purchase. The guarantee covers proven material faults, which will be corrected by us at no charge to you. As a precautionary measure, we are obliged to point out that we reserve the right to replace the unit if we deem the repair to be economically unviable.

Repairs which our Service department carries out for you do not extend the original guarantee period.

The guarantee does not cover damage caused by incorrect usage, e.g. reverse polarity, excessive vibration, excessive voltage, damp, fuel, and short-circuits. The same applies to defects due to severe wear.

We accept no liability for transit damage or loss of your shipment. If you wish to make a claim under guarantee, please send the device to the following address, together with proof of purchase and a description of the defect:

SERVICE ADDRESS

PowerBox-Systems GmbH
Dr.-Friedrich-Drechsler-Str. 35
86609 Donauwörth
Germany



12. SAFETY INFORMATION FOR THE INTENDED USE OF THE POWERBOX POWERPAK BATTERY SYSTEMS

Caution! Improper use can lead to fire, explosion, smoke development or chemical burns. Please read these instructions completely before using the battery. Lithium batteries have a high energy density. Improper handling can be dangerous. Strictly adhere to the manufacturer's instructions to avoid risks.

a) Intended use

- **PowerPaks** are intended exclusively for use in remote-controlled model applications, particularly in the field of model aircraft. They are not intended for manned aviation, safety-critical or medical applications. They may only be used by knowledgeable persons.

b) General safety instructions

- Be sure to read the entire operating instructions before use.
- Installation and connection may only be carried out when the system is switched off.
- Only use the battery for its intended purpose.
- Protect from moisture, rain, wet conditions and direct sunlight.
- Keep away from open flames, sparks and hot surfaces ($> 60\text{ }^{\circ}\text{C}$).
- Never disassemble, deform, pierce or open the battery.
- No short circuits: do not allow the contacts to come into contact with metal parts.
- Do not use damaged batteries (swelling, cracks, leakage).

c) Charging

- Only charge with chargers recommended by PowerBox-Systems.
- Do not exceed the charging parameters (voltage/current).
- Always supervise the charging process.
- Only charge on a non-flammable surface and in a safe environment.
- Allow the battery to cool to ambient temperature before charging.

d) Operation

- Install mechanically stress-free and vibration-damped in the model.
- Activate both batteries separately before each flight and check the voltage values.
- Only place in dry environments – do not allow to come into contact with water, moisture or fuel under any circumstances.
- Ensure adequate ventilation.
- Avoid overloading and deep discharge below the minimum voltage.

- In case of unusual heat development, smoke or odour: Disconnect immediately and store safely.
- Never open the device – this will void the warranty.

e) Approval information

- This device complies with the requirements of 2011/65/EU + 2015/863/EU (RoHS) and 2014/30/EU (EMC). For operation in other countries, country-specific approvals and regulations must be observed.

f) Transport & storage

- Insulate poles for transport (short-circuit protection).
- Transport in accordance with regulations (UN38.3, IATA, ADR).
- Store in a cool, dry place at 30-60 % charge.
- Do not store permanently fully charged or empty.

g) Disposal

- This product must not be disposed of with household waste. Hand it over to an appropriate collection centre for proper disposal (observe the WEEE Directive).

13. LIABILITY EXCLUSION

We are not in a position to ensure that you observe our instructions regarding installation of the **PowerPak**, fulfil the recommended conditions when using the unit, or maintain the entire radio control system competently.

For this reason we deny liability for loss, damage or costs which arise due to the use or operation of the **PowerPak**, or which are connected with such use in any way. Regardless of the legal arguments employed, our obligation to pay damages is limited to the invoice total of our products which were involved in the event, insofar as this is deemed legally permissible.

We wish you every success using your new **PowerPak**.



Donauwörth, March 2026

PowerBox-Systems GmbH

Dr.-Friedrich-Drechsler-Straße 35
86609 Donauwörth
Germany

 +49 906 99999-200

 sales@powerbox-systems.com

www.powerbox-systems.com