

# INSTRUCTION MANUAL

**PowerBox Systems®**

*World Leaders in RC  
Power Supply Systems*



# POWERSWITCH

**Dear customer,**

Congratulations on your decision to purchase the **PowerSwitch** from our range. We wish you many hours of pleasure and success with the **PowerSwitch**!

The **PowerSwitch** is an extremely durable, reliable mechanical switch. The switch itself is housed in a sealed, dustproof metal case. Four floating silver-plated double contacts switch the positive conductor alone. The negative conductor is looped through without contacts of any kind; this alone reduces the theoretical likelihood of failure by 50%! Two ball latches keep the switch in the selected switched position even when subjected to severe vibration.

The green LED shows the switched state; it is not a battery voltage indicator. The switch positions are marked on the case. The switch is ON when the slider is moved towards the LED - position **I**.

The **PowerSwitch** has also proved an excellent choice for ignition systems, and especially for **twin ignition systems** and **four-cylinder engines** with two ignition systems.

## **1. INSTALLATION**

The internal packaging is designed to be used as a template for marking the switch opening. Cut or saw out the opening outside the marked line.

Although the **PowerSwitch** is extremely resistant to vibration, it should always be installed in a position in the fuselage where vibration levels are low.

**Note:** The fuselage sides of large GRP power models are actually not suitable for mounting switches - regardless of type - because they are always subject to severe vibration and oscillation. You can remedy the situation by cutting a small plywood plate (2.5 to 3 mm thick) 2 to 3 cm larger than the switch opening, and gluing it on the inside of the fuselage at the appropriate point. When glued in place, the plate acts as a vibration damper, and also provides plenty of material for the switch retaining screws.

## 2. CONNECTIONS

The two connecting leads (blue / red) which are connected to the receiver or some other consumer unit consist of 0.34mm<sup>2</sup> cable. Always connect both plugs to the receiver: one to the receiver's battery socket, and the second to any other vacant channel output. This ensures that at least one connector contact carries current to the receiver and servos at all times. At the same time, the current required for your system is carried by both leads (twice the conductor cross-section) and both contacts, and this reduces voltage fluctuations and improves servo performance.

## 3. BATTERY TYPES

We always recommend the use of top-quality, low-impedance rechargeable batteries to power your receiving system. Any type of rechargeable battery (LiPo / Li-Ion, LiFe, NiCd / NiMH) up to 12.6V can be used. The PowerSwitch does not feature voltage regulation.

## 4. SPECIFICATION

Voltage range:

4.0 - 12.6V

Power supply:

LiPo/Li-Ion, LiFe, NiCd/NiMH

Max. continuous current:

up to 20 Ampere when switched on

Temperature range:

-10°C to +60°C

## 5. DIMENSIONS

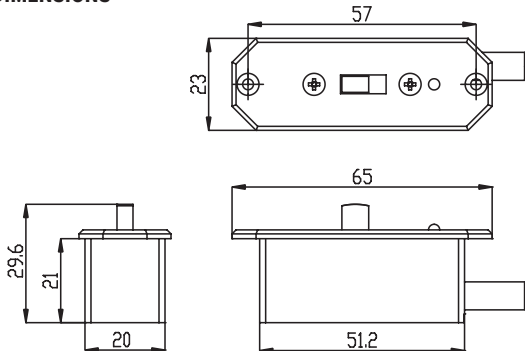

## 6. SET CONTENTS

- **PowerSwitch**
- Mounting screws
- Operating instructions in English and German
- Cutting template

## 7. SERVICE NOTE

We make every effort to provide a good service to our customers, and have now established a Support Forum which covers all queries relating to our products. This helps us considerably, as we no longer have to answer frequently asked questions again and again. At the same time it gives you the opportunity to obtain assistance all round the clock, and even at weekends. The answers come from the **PowerBox team**, which guarantees that the answers are correct.

Please use the Support Forum **before** you contact us by telephone.

You will find the forum at the following address:

**[www.forum.powerbox-systems.com](http://www.forum.powerbox-systems.com)**



## 8. GUARANTEE CONDITIONS

At **PowerBox-Systems** we insist on the highest possible quality standards in the development and manufacture of our products. They are guaranteed **“Made in Germany”!**

That is why we are able to grant a **24 month guarantee** on our **PowerSwitch** from the initial date of purchase. The guarantee covers proven material faults, which will be corrected by us at no charge to you. As a precautionary measure, we are obliged to point out that we reserve the right to replace the unit if we deem the repair to be economically unviable.

Repairs which our Service department carries out for you do not extend the original guarantee period.

The guarantee does not cover damage caused by incorrect usage, e.g. reverse polarity, excessive vibration, excessive voltage, damp, fuel, and short-circuits. The same applies to defects due to severe wear.

We accept no liability for transit damage or loss of your shipment. If you wish to make a claim under guarantee, please send the device to the following address, together with proof of purchase and a description of the defect:

### SERVICE ADDRESS

**PowerBox-Systems GmbH**  
Dr.-Friedrich-Drechsler-Str. 35  
86609 Donauwörth  
Germany

## 9. LIABILITY EXCLUSION

We are not in a position to ensure that you observe our instructions regarding installation of the **PowerSwitch**, fulfil the recommended conditions when using the unit, or maintain the entire radio control system competently.

For this reason we deny liability for loss, damage or costs which arise due to the use or operation of the **PowerSwitch**, or which are connected with such use in any way. Regardless of the legal arguments employed, our obligation to pay damages is limited to the invoice total of our products which were involved in the event, insofar as this is deemed legally permissible.

We wish you every success using your new **PowerSwitch**!



Donauwörth, December 2020

## **PowerBox-Systems GmbH**

Dr.-Friedrich-Drechsler-Straße 35  
86609 Donauwörth  
Germany



+49-906-99 99 9-200



sales@powerbox-systems.com

**[www.powerbox-systems.com](http://www.powerbox-systems.com)**