

We developed the **pitot slide** in order to avoid damage to the projecting pitot tube in transit. It enables the user to push the pitot tube into the model for transport, and then withdraw it again prior to flying. The integral magnets secure the slide in both positions. The **pitot slide** is supplied as a set of **GRP** components including the magnets, and can be assembled in just a few minutes using cyano-acrylate (CA) adhesive.

Content: a: 1x b: 1x c: 1x d: 1x e: 1x f: 2x g: 2x h: 2x

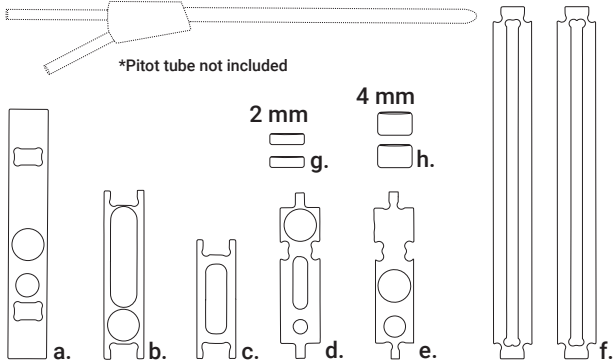

PITOT-SLIDE

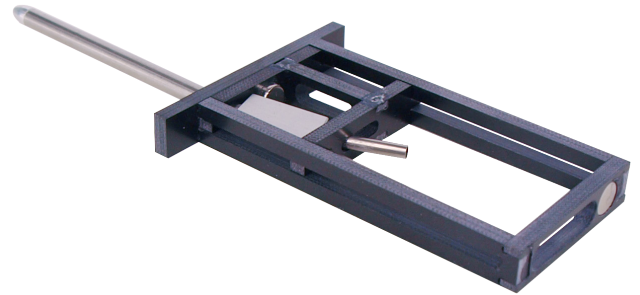

MANUAL

Assembly:

- Fit the parts together as shown in the illustrations.
- Note the correct position of the machined recesses for the magnets.
- Both the **4mm** magnets should be fitted to the front of the slide; the **2mm** magnets at the rear.
- Use low-viscosity (thin) cyano-acrylate adhesive.
- It is a good idea to apply silicone grease or similar lubricant to the contact surfaces to ensure that the slide moves smoothly.

TIP:

Use a non-magnetic stick, rod or pin to apply the adhesive to the joints; a length of solder works very well. If you apply the cyano-acrylate directly to the joints, and too much adhesive comes out, it is very easy to glue the sliding parts together!

1

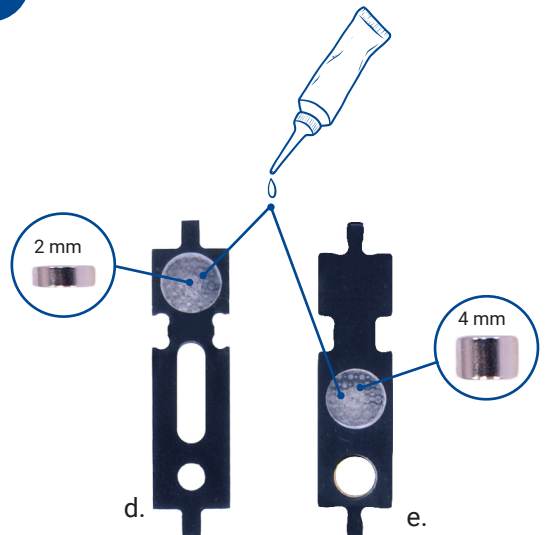

2

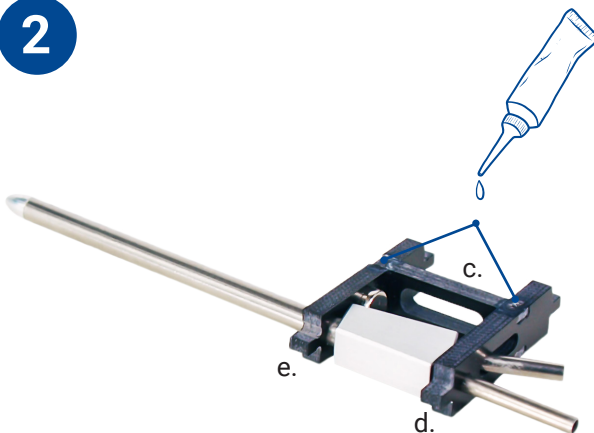

3

