

PowerBox Systems®

*World Leaders in RC
Power Supply Systems*

Instruction Manual



DIGISWITCH V2

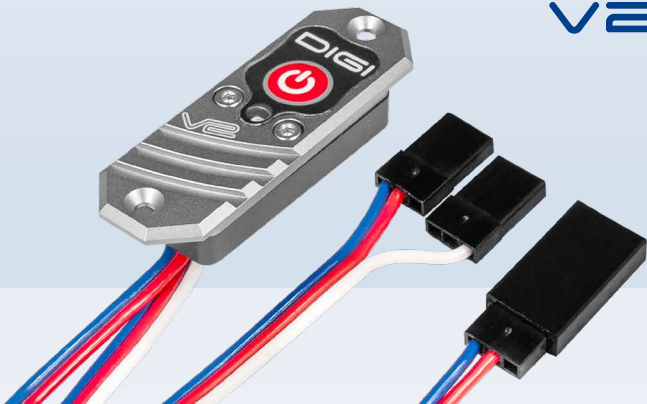

Dear customer,

congratulations on your decision to purchase the **PowerBox DigiSwitch V2** from our range. We wish you many hours of pleasure and success with the **PowerBox DigiSwitch V2!**

PRODUCT DESCRIPTION

The **PowerBox DigiSwitch V2** is the second generation of the **PowerBox Digi-Switch**, which is well-known throughout the world. For almost fifteen years the **PowerBox DigiSwitch** has represented the standard for small to medium-sized models thanks to its compact format and versatility.

By using the latest components we have been able to reduce the size of the **Digi-Switch V2** by about 20 %.

The introduction of a top-quality aluminium case, machined and anodised, has brought a substantial increase in the unit's cooling efficiency, with the result that the maximum continuous current capacity of the **PowerBox DigiSwitch V2** is around 20 % higher. In fact, the peak load capacity is twice as high: the **DigiSwitch V2** can handle more than 10 A for several seconds!

The **DigiSwitch V2** offers four user-selectable output voltages: for normal servos it can be set to a regulated 6.0 V, regulated voltages of 7.0 V and 7.6 V are available for HV servos, as is an option for non-regulated voltage.

Power to the unit can be drawn from four different battery types: LiPo, Lilon, LiFePo, NiMH. Ultra-bright RGB LEDs are fitted to indicate battery voltage; they light up in various colours to display the charge status of the batteries.

CORE users also benefit from one special additional feature: the battery voltage and regulator voltage can be displayed directly at the transmitter via telemetry!

FEATURES

- + High-performance electronic switch
- + Ultra-light unit, compact format
- + Regulated output voltage
- + User-selectable output voltage: 6.0 V/7.0 V/7.6 V or non regulated
- + RGB LED voltage indicator for the battery
- + Telemetry support for **CORE** systems
- + Supports 4 different battery types: 2s LiPo, 2s Lilon, 2s LiFePo and 5s NiMH
- + Regulator monitoring
- + Suppression of servo feedback currents

1. FEATURES AND CONNECTIONS

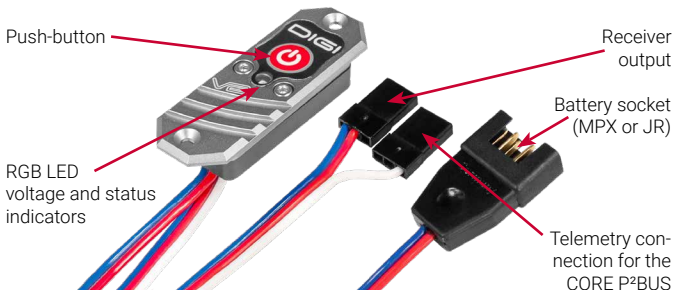

2. INSTALLING AND CONNECTING THE BATTERIES

The **PowerBox DigiSwitch V2** should be installed in the model in a position where vibration levels are low. Solid GRP fuselage sides in a power model should be fitted with an internal 3 – 4 mm thick plywood plate to minimise vibration, and to provide ‘meat’ for the retaining screws.

Connect the batterie of your choice – with correct polarity – to the battery input. You can use either 2s LiPo or Lilon, two 2s LiFePo or two 5s NiMH batteries. We recommend the use of **PowerPak 2.5x2 Pro** batteries, which are particularly safe and simple to handle thanks to their integral charge circuitry.

Note regarding home-assembled battery packs: connecting a battery to the unit with reversed polarity will immediately destroy the internal linear regulators!

Plug the output of the **DigiSwitch** into the receiver's Battery input or any vacant socket.

If there is no servo output available, a Y-lead can be connected to a servo output socket, to which the **DigiSwitch V2** and the servo are connected.

If you are using a **CORE** system, use the procedure described above. The cable with the single signal wire should be connected to the receiver's P²BUS input.

3. SWITCHING ON AND OFF

Like its predecessor, the **DigiSwitch V2** only has one button, and this simplifies the procedure for switching on and off. As with other **PowerBox** devices with a single button, the sequence is as follows:

Hold the button pressed in for one or two seconds until the LEDs light up violet. Now release the button for a moment before pressing it again briefly; this confirms the switching process.

Once switched on, the switch can only be switched off again using the button. Intermittent contacts or breaks while in use will not cause the **PowerBox** to switch off. The last switched status is always stored.

4. SETTING THE BATTERY DISPLAY

It is essential to set the correct battery type to ensure that the LED battery indicators work correctly. The first step is to switch the **PowerBox** on, then hold the button pressed in again.

After about five seconds the LEDs will go out, and a sequence of different colours begins. Each colour corresponds to a particular battery type. Simply release the button when the colour matching your battery type is displayed. The battery type is now stored.



Note regarding the LED display: the battery indicators do not follow battery voltage in a linear fashion. We have tested and measured various currently available battery types, and produced an average discharge curve from this information; this discharge curve is used as the basis for a percentage indication of battery state.

The LED indicators correspond to the battery status as follows:



5. SETTING THE OUTPUT VOLTAGE

The **PowerBox DigiSwitch V2** can be set to either of two output voltages: 6.0 V for conventional servos, and 7.0 V, 7.6 V or non-regulated for HV servos. If you opt for the higher setting, please ensure that all the components connected to the system are approved for high-voltage use.

One advantage of regulating the voltage at 7.6 V, instead of simply allowing the full battery voltage to pass through, is that it suppresses the high battery voltage present just after charging. The voltage remains stable right from the outset, which means that servo speed and power are constant for a longer period.

If you wish to change the output voltage, hold the button pressed in while you connect the battery. The LED will initially light up green, then switch to red after three seconds. Release the button when the colour is correct for your required output voltage: green = 6.0 V, orange = 7.0 V, violett = 7.6 V and red = non-regulated.



The LED now flashes white to confirm that the set-up process is complete.

Notes on regulator performance:

The maximum current which the **PowerBox DigiSwitch V2** can supply varies according to external factors such as battery type and the selected output voltage, and it is also significantly affected by cooling efficiency. Ideally the battery packer would be installed on the outside of the model, or inside in such a position that at least some airflow is present for cooling. In particular when the **DigiSwitch V2** is used with LiPo or Lilon cells, and the output voltage is set to 6.0 V, the number of servos connected to the system should not be excessive. At the same time please bear in mind that not all servos are equal: six small wing servos draw less current than four 30 kg types.

At the 7.6 V setting the backer does not have to work hard to regulate the voltage and disperse energy. This increases the performance of the **PowerBox DigiSwitch V2** substantially. The same applies to the 6.0 V output voltage setting if LiFePo or NiMH batteries are used, since the input voltage at the **DigiSwitch** is already lower.

If you are not sure whether the **PowerBox DigiSwitch V2** has sufficient capacity for the requirements of your system, move all the servos continuously - with the model on the ground - for about thirty seconds. If the **DigiSwitch V2** becomes hot to the touch (more than 60°C), first check that the servos, pushrods and linkages are in good order. If you find no problems, then you should use the **PowerBox Sensor** instead, as it is better suited to heavy-duty work.

6. REGULATOR ERRORS

The unit constantly monitors the operation of the voltage regulators. If the output voltage strays outside the correct value, the LEDs indicate this by lighting up violet and flashing rapidly. Regulator errors typically occur when a battery is connected with reversed polarity.

If this should happen, please contact our Service department!

7. SPECIFICATION

Operating voltage:	4,0 V – 9,0 V
Power supply:	2s LiPo, 2s Lilon, 2s LiFePo, 5s NiMh
Current drain, operating	23 mA
Current drain, stand-by:	4 μ A
Peak current capacity:	10 A
Drop-out voltage:	0.1 V
Output voltage:	6.0 V/ 7.0 V/7.6 V stabilised or non-regulated
Supported telemetry system:	P ² BUS
Dimensions:	50 x 18 x 11 mm
Weight:	15 g
Temperature range:	-30 °C to +105 °C

8. DIMENSIONS

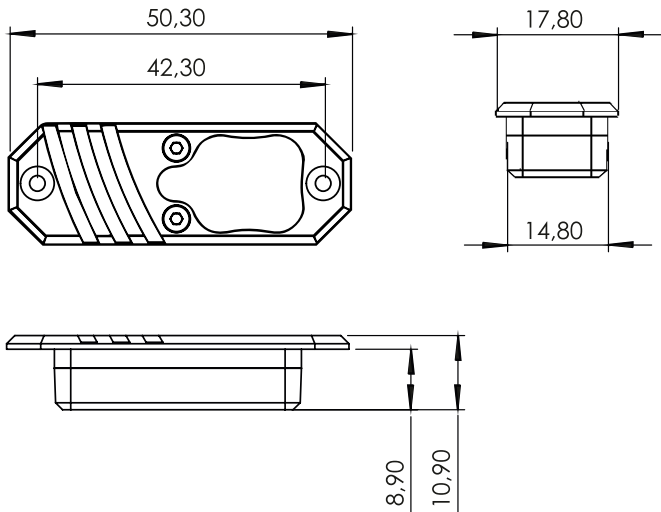

9. SET CONTENTS

- **PowerBox DigiSwitch V2**
- 2x retaining screws
- Operating instructions in English and German

10. SERVICE NOTE

We are anxious to offer good service to our customers, and to this end we have set up a Support Forum which deals with all queries concerning our products. This relieves us of a great deal of work, as it eliminates the need to answer frequently asked questions time and again. At the same it gives you the opportunity to obtain help quickly all round the clock – even at weekends. All the answers are provided by the **PowerBox Team**, guaranteeing that the information is correct.

Please use the Support Forum **before** you telephone us.

You can find the forum at the following address:

www.forum.powerbox-systems.com

11. GUARANTEE CONDITIONS

At **PowerBox-Systems** we insist on the highest possible quality standards in the development and manufacture of our products. They are guaranteed **“Made in Germany”!**

That is why we are able to grant a **24 month guarantee** on our **PowerBox Digi-Switch V2** from the initial date of purchase. The guarantee covers proven material faults, which will be corrected by us at no charge to you. As a precautionary measure, we are obliged to point out that we reserve the right to replace the unit if we deem the repair to be economically unviable.

Repairs which our Service department carries out for you do not extend the original guarantee period.

The guarantee does not cover damage caused by incorrect usage, e.g. reverse polarity, excessive vibration, excessive voltage, damp, fuel, and short-circuits. The same applies to defects due to severe wear.

We accept no liability for transit damage or loss of your shipment. If you wish to make a claim under guarantee, please send the device to the following address, together with proof of purchase and a description of the defect:

SERVICE ADDRESS

PowerBox-Systems GmbH

Ludwig-Auer-Straße 5
D-86609 Donauwoerth
Germany

12. LIABILITY EXCLUSION

We are not in a position to ensure that you observe our instructions regarding installation of the **PowerBox DigiSwitch V2**, fulfil the recommended conditions when using the unit, or maintain the entire radio control system competently.

For this reason we deny liability for loss, damage or costs which arise due to the use or operation of the **PowerBox DigiSwitch V2**, or which are connected with such use in any way. Regardless of the legal arguments employed, our obligation to pay compensation is limited to the invoice total of our products which were involved in the event, insofar as this is deemed legally permissible.

We wish you every success with your new **PowerBox DigiSwitch V2**.

A handwritten signature in blue ink, consisting of stylized, cursive letters that appear to be 'D. H. R.' followed by a small horizontal line.

Donauwoerth, December 2020

PowerBox-Systems GmbH

Ludwig-Auer-Straße 5
D-86609 Donauwoerth
Germany



+49-906-99 99 9-200



+49-906-99 99 9-209

www.powerbox-systems.com