



World Leaders in RC
Power Supply Systems

Instruction Manual



POWERBOX EVO

The **PowerBox Evo** is an ultra-compact dual power supply featuring 7 channels, regulated output voltage and telemetry. The 7 inputs are assigned to 10 outputs, allowing two servos to be controlled in parallel on each of 3 channels, without requiring additional Y-leads. All servo outputs have integral signal amplification and are protected against servo feedback currents.

The **PowerBox MicroSwitch** included in the set is not subject to wear, and operates both electronic switches reliably. It is also used to set the output voltage and the battery type.

By default the two high-performance voltage regulators deliver 6.0V, but that value can easily be changed to 7.4V, 7.8V or no regulation at all using the **PowerBox MicroSwitch**. The machined aluminium heat-sink ensures a high continuous load capacity.

The **PowerBox Evo** supports all current telemetry systems: PowerBox, Jeti, Futaba, Multiplex, Graupner, Spektrum and JR, which means that the voltage of both batteries can be monitored conveniently from the transmitter. It is also possible to read off the state of charge of the batteries at any time using the two tri-colour LEDs.

Features:

- 7 channels
- 10 outputs
- High-performance battery backer with high continuous load capacity
- All power electronics duplicated
- Redundant electronic switch
- Four selectable output voltages: 6.0V, 7.4V, 7.8V or unregulated

- Telemetry data for PowerBox P²BUS, Futaba S.BUS2, Jeti Ex-BUS, Spektrum SRXL2, Multiplex M-Link, JR X-BUS and Graupner HoTT
- All features can be controlled from PowerBox and Jeti transmitters
- Signal amplification for all 10 outputs
- Voltage indication by means of tri-colour LEDs
- Supports four battery types: LiPo, Lilon, NiMh/NiCd, LiFe
- Servo feedback current suppression
- Machined high-performance heat-sink for optimised heat dissipation
- Machined, anodised aluminium switch case
- Compact format

1. INSTALLATION, CONNECTIONS

a) Mounting

The Evo should be attached to a robust sub-structure using the four screws, rubber grommets and brass sleeves supplied in the set; the switch should be mounted in the fuselage side. We recommend reinforcing the switch aperture on the inside of the fuselage with a layer of wood to protect the unit from severe vibration; this is particularly important in models with a GRP fuselage. An external switch is often undesirable on a scale model, and for such applications we offer the **PowerBox MicroMag** as an alternative. However, please note that - unless you are using a PowerBox or Jeti system - the **PowerBox MicroSwitch** is required for programming the battery type and the output voltage.

The **PowerBox MicroSwitch** is connected to the socket marked **Switch** on the side of the **PowerBox Evo**. In models where severe vibration is likely to occur, we recommend that the ribbon cable should be secured at a minimum of one additional point

to avoid the plug working loose. If the ribbon cable were to fall out, it would have no effect on the backer's switched state, but would make it impossible to switch the system off.

b) Receiver

Start by connecting all the servos to the appropriate channels; the assignment is entirely up to you. For example: input 4 corresponds to output 4, but whether you connect the aileron servo or the throttle servo is a matter of your choice.

Channels 3 – 4 – 5 each have two outputs, allowing you to connect two servos without a Y-lead. But please note: the **PowerBox Evo** does not feature servo matching, so the servos must be adjusted mechanically for equal travel if both are connected to the same control surface.

Connect the receiver using the seven patch leads supplied in the set. Power is fed to the receiver through these leads.

Connect the telemetry patch lead to the Telemetry input on your receiver as follows:

PowerBox:	P ² -BUS
Jeti:	EX-BUS
Futaba:	S.BUS2
Spektrum:	SRXL2
Graupner:	Hott
Multiplex:	Sensor
JR:	Sens

The telemetry system is detected automatically, so you do not have to make any further adjustments.

c) Batteries

The final step is to connect the batteries to the MPX sockets on the backer. We recommend that you use our **PowerPacks 2.5 x 2**.

Caution: If you intend to use other makes of battery, or packs you have assembled yourself, please take great care to maintain correct polarity - better to check twice! Connecting a battery just once with reverse polarity will always destroy the backer's regulators. The unit does not feature polarity protection, in order to minimise power losses. The + indicator is engraved on the heat-sink.

2. SWITCHING ON

The push-button switch operates in the same way as all PowerBox systems: hold the button pressed in until the LED starts to flash green at a high rate. Briefly release the button, then press it again. The LED now lights up a constant green, indicating that the unit is switched on.

Repeat the procedure to switch off.

If you are using a **PowerBox MicroMag**, hold the magnet against the switch until the **PowerBox Evo** turns itself on. The LED lights up blue as soon as a magnet is detected. The LED turns red to indicate the end of the switching process; after this the LED glows green to indicate that it is switched on.

3. SETTING THE BATTERY TYPE

It is important to set the battery type, otherwise the LED battery indicator cannot work properly. This is the procedure: first switch the **PowerBox** on, then hold the button pressed in again.

After about five seconds the LEDs go out, and a sequence of different colours commences, each colour corresponding to one battery type. Release the button when the LEDs light up in the colour corresponding to your battery type. Both LEDs flash white to confirm the setting, and the battery type is then stored.



Information on the LED display: the display does not correspond to battery voltage in a linear manner. We have measured different battery types in current use to produce an average discharge curve. This discharge curve is used in order to provide a percentage display.

The LED display corresponds to the battery capacity in the following way:



PowerBox and Jeti users can also carry out this adjustment directly at the transmitter. You will find the setting in the EVO Telemetry menu on **PowerBox** transmitters, and in the JetiBox application with a Jeti system.

4. SETTING THE OUTPUT VOLTAGE

The **PowerBox Evo** can be set to four different output voltages: on the one hand to 6.0V for conventional servos, on the other to 7.4V, 7.8V or completely unregulated for HV servos.

If you intend using the last named setting, please ensure that all components connected to the system are safe for use on high voltage.

The advantage of regulating the voltage at 7.4V or 7.8V, instead of simply allowing the full battery voltage through, is that it reduces the high battery voltage which is present immediately after charging. A constant voltage is then fed to the system right from the outset, ensuring consistent servo speed and power over a long period.

To change the output voltage, connect one of the batteries whilst holding the button pressed in. The LED will initially light up green, then turn orange after three seconds, then violet after six seconds, and finally red after a further nine seconds. The output voltage is set in accordance with the LED colour when you release the button. The output voltage assignment is as follows:



Finally the LED flashes white to confirm that the setup procedure is complete. Disconnect the battery, and repeat the procedure with the second battery socket.

PowerBox and Jeti users can also change this setting directly at the transmitter. You will find the setting in the EVO Telemetry menu on **PowerBox** transmitters, and in the JetiBox application with a Jeti system.

5. SPECIFICATION

Operating voltage:	4.0V - 9.0V
Power supply:	2S LiPo, 2S Lilon, 2S LiFePo, 5S NiMH
Current drain, operating:	66mA
Current drain, standby:	8 μ A
Continuous load capacity:	2 x 10 A (<30s 2 x 40A)
Dropout voltage:	0.3V
Output voltage:	6.0V, 7.4V, 7.8V, unregulated
Channels:	7
Servo outputs:	10
Supported telemetry systems:	P ² BUS, S.BUS2, EX-Tele, SRXL2, M-Link, Hott, JR
Dimensions:	89 x 55 x 18mm
Weight:	69g
Weight of Sensor Switch:	8g
Temperature range:	-30°C to +105°C

6. SET CONTENTS

- **PowerBox Evo**
- **MicroSwitch**
- 8x patch leads
- 6x fixing screws
- 4x rubber grommets and brass sleeves
- Operating instructions

7. DIMENSIONS

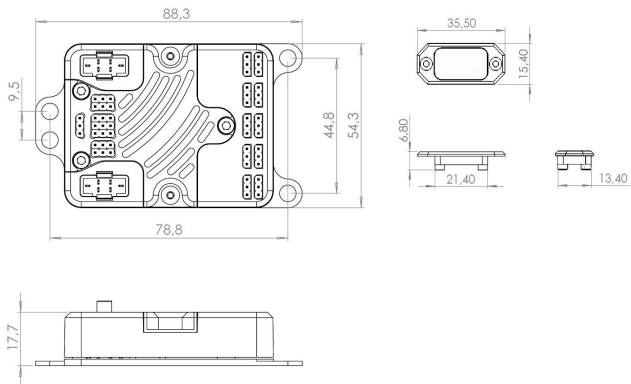

8. SERVICE NOTE

We are anxious to offer good service to our customers, and to this end we have set up a Support Forum which deals with all queries concerning our products. This relieves us of a great deal of work, as it eliminates the need to answer frequently asked questions time and again, and it gives you the opportunity to obtain help quickly all round the clock - even at weekends. All the answers are provided by the **PowerBox Team**, guaranteeing that the information is correct.

Please use the Support Forum before you telephone us. You will find the forum at the following address:

www.forum.powerbox-systems.com

9. GUARANTEE CONDITIONS

At **PowerBox-Systems** we insist on the highest possible quality standards in the development and manufacture of our products. They are guaranteed **“Made in Germany”!**

That is why we are able to grant a **24 month guarantee** on our **PowerBox EVO** from the initial date of purchase. The guarantee covers proven material faults, which will be corrected by us at no charge to you. As a precautionary measure, we are obliged to point out that we reserve the right to replace the unit if we deem the repair to be economically unviable.

SERVICE ADDRESS

PowerBox-Systems GmbH
Ludwig-Auer-Straße 5
86609 Donauwoerth
Germany

10. LIABILITY EXCLUSION

We are not in a position to ensure that you observe our instructions regarding installation of the **PowerBox Evo**, fulfil the recommended conditions when using the unit, or maintain the entire radio control system competently.

For this reason we deny liability for loss, damage or costs which arise due to the use or operation of the **PowerBox Evo**, or which are connected with such use in any way. Regardless of the legal arguments employed, our obligation to pay damages is limited to the invoice total of our products which were involved in the event, insofar as this is deemed legally permissible.

We wish you every success using your new **PowerBox Evo**.

A handwritten signature in blue ink, appearing to be 'D&R', is written over a horizontal line.

Donauwoerth, February 2023

PowerBox-Systems GmbH

Ludwig-Auer-Straße 5
86609 Donauwoerth
Germany



+49-906-99 99 9-200



+49-906-99 99 9-209

www.powerbox-systems.com